



Comparison of crop water requirement using aqua crop model and pan evaporimeter in zai pit technology and furrow irrigation methods

Vani G¹, Subhasree N², Vinayak M³, Ratna Raju Ch⁴

¹ Department of Food Processing Engineering, CIAE, Bhopal, Madhya Pradesh, India

² Department of Soil and Water Engineering, ANGRAU, Dr. NTR College of Agricultural Engineering, Bapatla, Andhra Pradesh, India

³ Assistant Professor, Department of Agricultural Engineering, Aditya University, Surampalem, Andhra Pradesh, India

⁴ Assistant professor, Department of Irrigation and Drainage Engineering, ANGRAU, Dr. NTR College of Agricultural Engineering, Bapatla, Andhra Pradesh, India

Abstract

Agriculture is a backbone of Indian economy India has facing number of problems which include increasing in population, depletion of water availability, runoff and cultivated land. India only 34% of the water resources is an available to meet the increasing demands of agriculture, industry and urban usage. The quality and availability of water are two major factor that affects irrigation in crops. Adequate is essential for good germination of all crops. Irrigated lands now produce 4% of the food supply which doesn't meet the required supply to avoid all the above problems, a new sustainable land and water management technique is introduced which is called Zai pit method. Zai pit technology provides a window of opportunity for farmers to improve crop performance in harsh & changing climate. This method increases the amount of water stored in the soil profile by trapping rain water. The methodology follows Zai pit technology resulted in high tomato yield of (4081.63 kg/ ha) compared to furrow irrigation of (2040.81 kg/ha) respectively. Plant growth in zai pit technology is observed more uniform compared with furrow irrigation. Field water use efficiency of zai pit technology (13.84 kg/ha-mm) is 4 times more when compared with furrow irrigation (3.05 kg/ha-mm).

Keywords: Zai pit technology, furrow irrigation, crop evapotranspiration, aqua crop model, pan evaporimeter, water use efficiency, field water use efficiency

Introduction

The population of India is expected to stabilize around 1640 million by the year 2050. Moreover, every year the population will increase but the cultivated lands will not increase, to meet the required food supply. So, it is necessary to convert the barren lands into cultivable lands with better land and water management to provide required food supply. Gross per capita water availability will decline from 1820 cu. m/ year in 2001 to as low 1140 cu.m/year in 2050. Increase in population and depletion of ground water resources is the major problem for food security and stability. Irrigated lands now produce 4% of the food supply which doesn't meet the required supply. Therefore, it is necessary to choose a suitable irrigation method and convert the uncultivated land into cultivated land for getting an optimum yield which meet the necessary requirement with available water by applying best irrigation management practices. Furthermore, good management and timely application of water may result in preventing of land degradation. The crop water requirement always refers to a crop grown under optimal conditions, i.e. a uniform crop, actively growing, completely shading the ground, free of diseases, and favourable soil conditions (including fertility and water). Accurate crop water requirement data are essential in irrigated agriculture. An appraisal of economic returns from irrigation projects and proper design and

operation of irrigation scheme depends, to a large extent, on the reliability of available information on crop water requirements. Precise knowledge of crop water requirements is also needed for efficient use of limited irrigation water. To optimize the limited resources available the best input is the yield response to water which is often simulated with empirical water production function at present, dynamic crop simulation model, such as AquaCrop. As well known, actual crop evapotranspiration (ET) is a major term of water budget in agriculture and it is the main variable used to determine crops water requirement.

As compared to other crop models, Aqua Crop has a significantly smaller number of parameters and a better balance between simplicity, accuracy and robustness. Root zone water content is simulated by keeping track of incoming and outgoing water fluxes at its boundaries, considering the soil as a water storage reservoir with different layers. Instead of leaf area index, Aqua Crop uses canopy ground cover. Canopy development, stomatal conductance, canopy senescence and harvest index are the key physiological crop responses to water stress. Evapotranspiration is simulated as crop transpiration and soil evaporation and the daily transpiration is used to derive the daily biomass gain via the normalized biomass water productivity of the crop. The normalization is for reference evapotranspiration and CO₂ concentration to make the

model applicable to diverse locations and seasons, including future climate scenarios. AquaCrop accommodates different water management systems, including rainfed agriculture and supplemental, deficit, and full irrigation. As compared to other crop models, Aqua Crop has a significantly smaller number of parameters and a better balance between simplicity, accuracy and robustness. Root zone water content is simulated by keeping track of incoming and outgoing water fluxes at its boundaries, considering the soil as a water storage reservoir with different layers. Instead of leaf area index, Aqua Crop uses canopy ground cover. Canopy development, stomatal conductance, canopy senescence and harvest index are the key physiological crop responses to water stress. Evapotranspiration is simulated as crop transpiration and soil evaporation and the daily transpiration is used to derive the daily biomass gain via the normalized biomass water productivity of the crop. The normalization is for reference evapotranspiration and CO₂ concentration to make the model applicable to diverse locations and seasons, including future climate scenarios. AquaCrop accommodates different water management systems, including rainfed agriculture and supplemental, deficit, and full irrigation.

As compared to other crop models, AquaCrop has a significantly smaller number of parameters and a better balance between simplicity, accuracy and robustness. Root zone water content is simulated by keeping track of incoming and outgoing water fluxes at its boundaries, considering the soil as a water storage reservoir with different layers. Instead of leaf area index, AquaCrop uses canopy ground cover. Canopy development, stomatal conductance, canopy senescence and harvest index are the key physiological crop responses to water stress. Evapotranspiration is simulated as crop transpiration and soil evaporation and the daily transpiration is used to derive the daily biomass gain via the normalized biomass water productivity of the crop. The normalization is for reference evapotranspiration and CO₂ concentration to make the model applicable to diverse locations and seasons, including future climate scenarios. AquaCrop accommodates different water management systems, including rainfed agriculture and supplemental, deficit, and full irrigation (Steduto, 2008) [14]. As compared to other crop models, Aqua Crop has a significantly smaller number of parameters and a better balance between simplicity, accuracy and robustness. Root zone water content is simulated by keeping track of incoming and outgoing water fluxes at its boundaries, considering the soil as a water storage reservoir with different layers. Instead of leaf area index, AquaCrop uses canopy ground cover. Canopy development, stomatal conductance, canopy senescence and harvest index are the key physiological crop responses to water stress. Evapotranspiration is simulated as crop transpiration and soil evaporation and the daily transpiration is used to derive the daily biomass gain via the normalized biomass water productivity of the crop. The normalization is for reference evapotranspiration and CO₂ concentration to make the model applicable to diverse locations and seasons, including

future climate scenarios. AquaCrop accommodates different water management systems, including rainfed agriculture and supplemental, deficit, and full irrigation.

The normalization is for reference evapotranspiration and CO₂ concentration to make the model applicable to diverse locations and seasons, including future climate scenarios. AquaCrop accommodates different water management systems, including rainfed agriculture and supplemental, deficit, and full irrigation.

1. Zai pit method

Zai is traditional land rehabilitation technology. Zai pit technology provides a window of opportunity for farmers to improve crop performance in harsh & changing climate. This method increases the amount of water stored in the soil profile by trapping rain water. It retains moisture and holds water long enough to allow it to infiltrate. It promotes the efficient use of limited quantities of organic matter and ensures the concentration of water & soil fertility.

Zai technology also reactivates biological activities in the soil and eventually leads to an improvement in soil structure. This eventually leads to less desertification. The poorly available organic matter is placed at the bottom of the pit and not broadcast over the whole field. The organic material used attracts termites, which play a crucial role as they dig channels in the soil and by doing so improve its "architecture". The termites also digest the organic material, making nutrients more easily available to the crops planted or sown in the pits.

Materials and Methods

The seedlings of the tomato were brought from the local nursery, Madakasira. The seedlings grown in portraits under shade net with the age of 25 days were selected for present study.

Table 1: Crop details of tomato crop

Crop name	Tomato
Variety	Sakata
Duration	90 days
Row spacing	80cm
Plant spacing	80cm

1. Field Preparation

Before ploughing the soil, FYM (Farm Yard Manure) was applied to the furrow irrigation site. The field was ploughed well to bring to optimum tilth. The ploughing provides opening of soil, crushing of clods, destroy the weeds and utilize the micro nutrients for crop growth.

2. Planning and Design of Experiment

The experimental field with total area of 196 m² was selected for experimentation. The total area was divided into 2 plots i.e., one plot for zai pit technology and another plot for furrow irrigation method. Both plots having 98m² (7 m×14 m) area was selected for experimentation. The spacing for tomato crop was selected about 80 × 80 cm for experimentation.

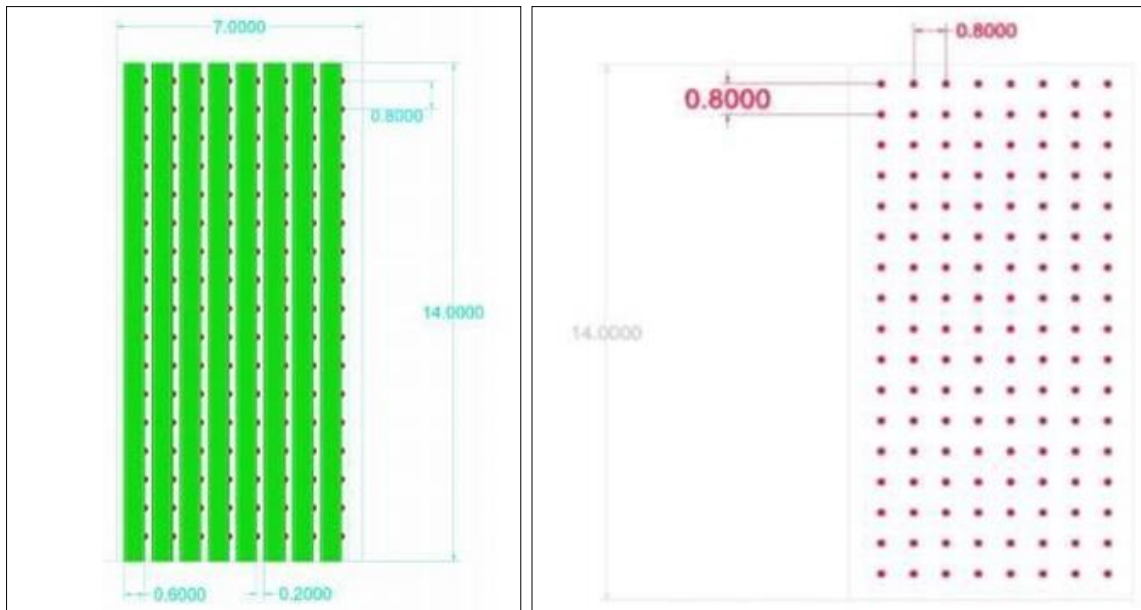

Fig 1: Layout of zai pit and furrow irrigation at CAE Madakasira

3. Transplanting of Tomato Seedlings

The seedlings were transplanted into the field on 8th February, 2018. Light irrigation was done immediately after transplanting. Gap filling was done on fourth day of transplanting.

4. Evapotranspiration

Evaporation and transpiration occur simultaneously and there is no easy way of distinguishing between the two processes. Apart from the water availability in the topsoil, the evaporation from a cropped soil is mainly determined by the fraction of the solar radiation reaching the soil surface. This fraction decreases over the growing period as the crop develops and the crop canopy shades more and more of the ground area. When the crop is small, water is predominately lost by soil evaporation, but once the crop is well developed and completely covers the soil, transpiration becomes the main process.

The evapotranspiration rate is normally expressed in millimetres (mm) per unit time. The rate expresses the amount of water lost from a cropped surface in units of water depth. The time unit can be an hour, day, month or even an entire growing period or year.

4.1 Pan Evaporation Method

Evaporation pans provide a measurement of the combined effect of temperature, humidity, wind speed and sunshine on the reference crop evapotranspiration ET_0 . Many different types of evaporation pans are being used. The best-known pan is the Class A evaporation pan (circular pan) (Fig 3). The procedure for class A evaporation pan as

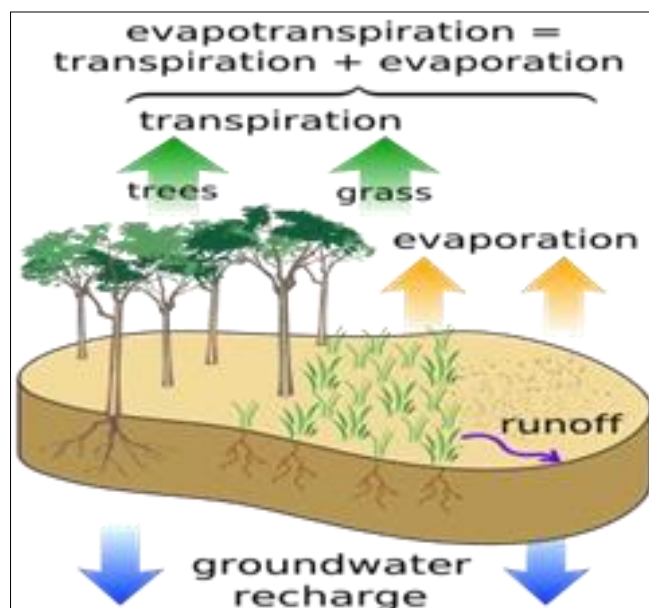

Fig 2: Process of evapotranspiration

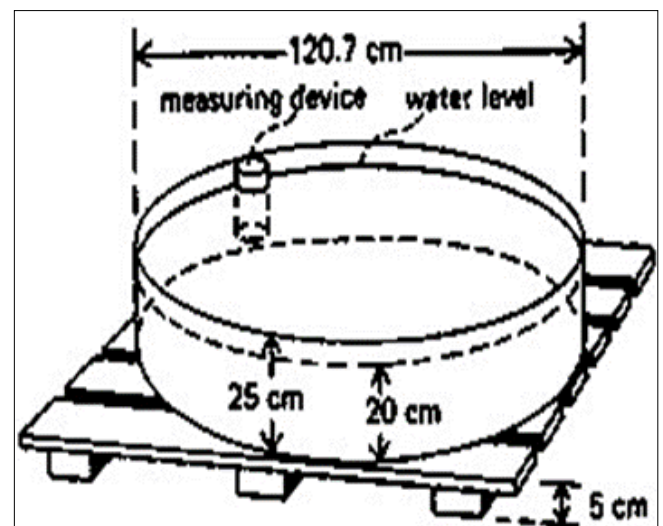

Fig 3: Class A pan evaporimeter

The evaporation pan was installed in the field. The pan was filled with a known quantity of water, after that water is allowed to evaporate during a certain period of time (usually 24 hours). After 24 hours, the remaining quantity of water (i.e. water depth) was measured. The amount of evaporation per time unit (difference between the two measured water depths) was calculated; this is the pan evaporation: E_{pan} (in

mm/24 h). The E pan was multiplied by a pan coefficient, K pan, to obtain the ET_o (ET_o = K pan × E pan), Where ET_o= Reference evapotranspiration, K pan= pan coefficient, E pan= pan evaporation

4.2 Determination of K pan

When using the evaporation pan to estimate the ET_o, in fact, a comparison is made between the evaporation from the water surface in the pan and the evapotranspiration of the standard grass. Of course, the water in the pan and the grass do not react in exactly the same way to the climate. Therefore, a special coefficient is used (K pan) to relate one to the other. The pan coefficient, K pan, depends on: The type of pan used, the pan environment: if the pan is placed in a fallow or cropped area, climate: the humidity and wind speed. For the Class A evaporation pan, the K pan varies between 0.35 and 0.85. Average K pan = 0.70.

5. Aqua Crop 6.0 Model

Aqua Crop is a crop water productivity model developed by the Land and Water Division of FAO (Rome). It simulates yield response to water of herbaceous crops, and is particularly suited to address conditions where is a key limiting factor in crop production.

Aqua Crop-6.0 is a program developed by Food and Agricultural Organization of the United Nations (October 2015) to evaluate the ET_o (Evapotranspiration), NIR (Net irrigation requirement), Dry yield, above-ground Biomass, simulated Canopy Cover (CC), Salinity Stress with the help of field data stored in an observation file data. The schematic representation of functional elements and main components in AquaCrop model (steduto *et al*) shown in fig.

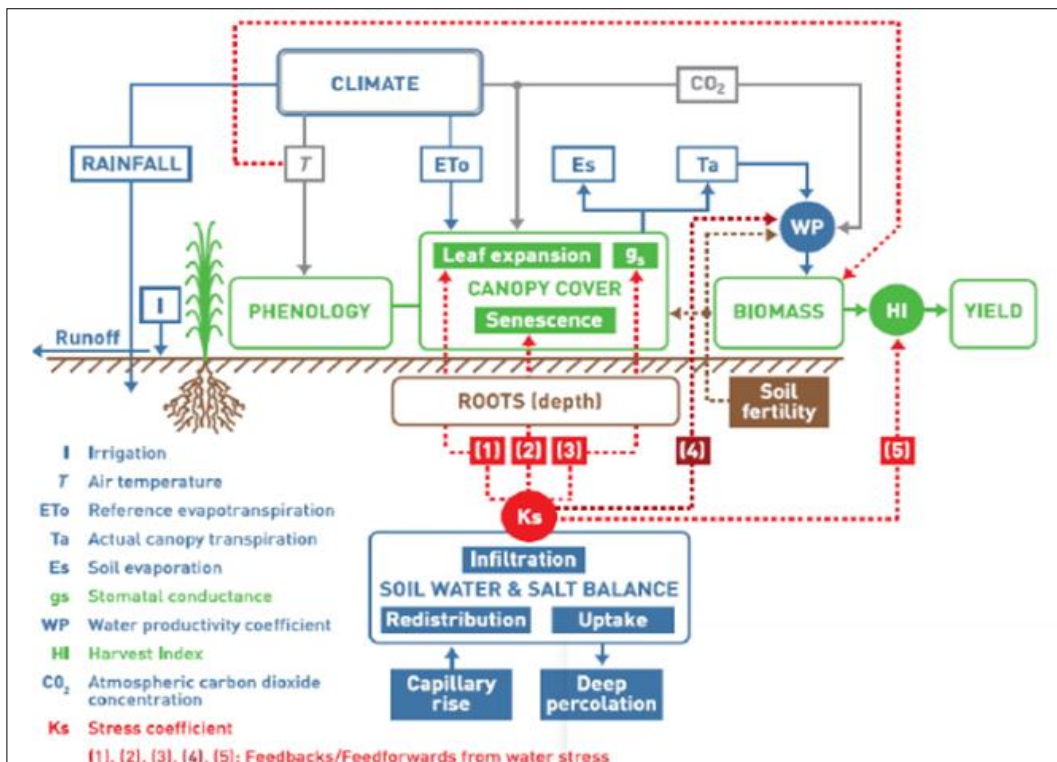

Fig 4: Flowchart of Aqua Crop indicating the main components of the soil-plant-atmosphere continuum

5.1 Data Required

The initial data that are needed for the model in order to get the irrigation crop water requirements are summarized as the following:

- Climate data
- Crop data
- Management data
- Soil data

5.2 Climate Data

Climate data for the present study have been collected from the Agricultural Research Station, Pavagada, Karnataka. The following parameters have been calculated from the above collected weather data:

- Rainfall
- Average minimum and maximum air temperature in ° C
- Average Relative Humidity in %
- Wind speed in m/s

- Solar radiation MJ/sq.m.

5.3 Crop Data

In the crop data insert the transplanting or sowing date, the crop type (either C₃ or C₄) plantation method, cropping period and length of growing cycle which used in the experimentation.

5.4 Management Data

The management data consist of two types of data sets *i.e* irrigation data field data. But in this research only irrigation data was used.

5.5 Irrigation Data

In this data irrigation method, quality of irrigation water and irrigation events have to be specified as per the experimentation plan for calculations of net irrigation requirement and irrigation schedule.

5.6 Soil Data

The soil data consist of two types of data sets *i.e* soil profile data and ground water data. But in this project only soil profile data was used.

5.7 Soil profile Data

In soil profile data specify number of horizons and type of soil with thickness of layer.

6. Water Use Efficiency

The term water use efficiency denotes the production per unit of water applied. It is expressed as the weight of crop produce per unit depth of water over a unit area, *i.e.*, kg/cm per hectare. Two distinct terms are used in expressing water use efficiency.

a. Crop water use efficiency: It is the ratio of crop yield (Y) to the amount of water depleted by the crop in the process of evapotranspiration (ET).

$$\text{Crop water use efficiency} = \frac{Y}{ET}$$

b. Field water use efficiency: It is the ratio of crop yield (Y) to the total amount of water used in the field (WR)

$$\text{Field water use efficiency} = \frac{Y}{WR}$$

Results and Discussion

1. Estimation and Comparison of Crop Evapotranspiration Using Aqua Crop Model and Pan Evaporimeter

Comparison of average ET_c values for the interval of 10 days using aqua crop model and pan evaporimeter was presented in Table 2. The reference evapotranspiration was multiplied with tomato crop coefficients due to this crop evapotranspiration was obtained. Total crop evapotranspiration of tomato crop was equal to 50mm of water used for nursery bed preparation, 68 mm of rainfall received during crop period and 393.7 mm of crop evapotranspiration obtained from pan evaporimeter *i. e* 511.7 mm and it was presented in Table 2. The crop evapotranspiration was also predicted with AQUACROP Model 6.0 and it was predicted as 443.7 mm and it was presented in Table 2. From the Figure 5 it was observed that in AQUACROP model total evapotranspiration is decreased compared to pan evaporimeter.

Table 2: Comparison of average ET_c values for the interval of 10 days using aqua crop model and pan evaporimeter

S. No	MODEL	DAYS								
		1-10	11-20	21-30	31-40	41-50	51-60	61-70	71-80	81-91
1	PAN ET _c	2.142	3.108	3.15	4.347	4.66	5.55	6.923	3.696	5.24
2	AQUACROP MODEL ET _c	1.472	1.686	2.02	5.247	5.727	5.75	5.75	4.09	3.534

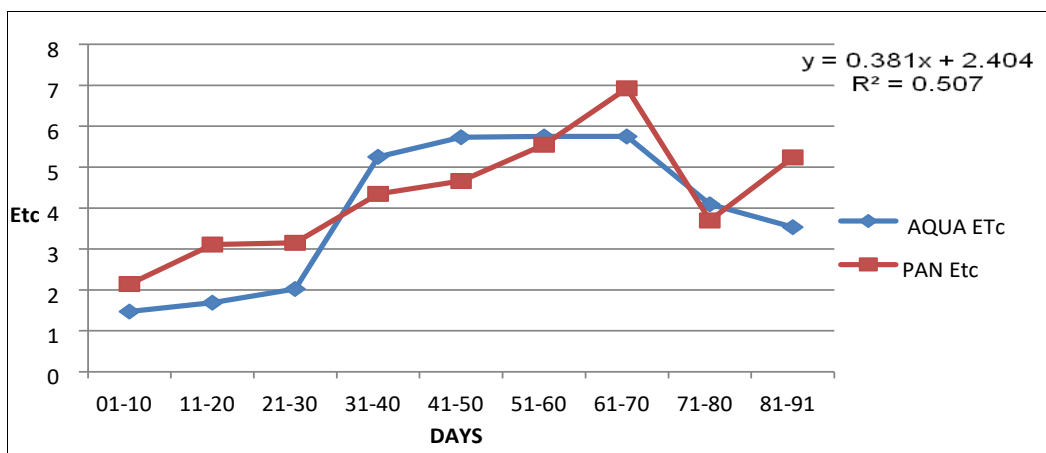

Fig 5: Comparison of ET_c pan & Aqua crop model

From the Fig 3.1 shows that ET varies between 1- and 2-mm during tillering and increased rapidly with crop development to 3-6 mm during mid sesason stage and decrease in ET was observed thatharvesting stage. In comparison, the difference in measured and estimated values could results from measurement method. Several authours reported on cases of underestimation of ET by Ec method (Twine *et al*,2000; Evett *et al*.2012a, 2012 b) [4, 15].

In the present work, the difference in estimated and measured values may be the aerodynamic resistance, dependent on wind direction and field slope (rana *et al*.2007) [12]. Similar results were obtained by Boudhina *et al*,2018.

2. Crop Water Use Efficiency

Table 3: Comparison of crop water use efficiency between zai pit technology and furrow irrigation method for both aqua crop model and pan evaporimeter

S. No	Crop	Type of method	Crop water use efficiency (Kg/ha-mm)	
			AQUA CROP model	Pan evaporimeter
1	Tomato	Zai pit technology	10.41	7.97
2		Furrow irrigation method	5.18	3.98

From the Table 3 it was observed that, the crop water use efficiency is found highest in zaipit technology with the values of 10.41 Kg/ha-mm in AQUACROP model and 7.97Kg/ha-mm in pan evaporimeter compared with furrow irrigation method values of 5.18 Kg/ha-mm in AQUA CROP model and 3.98 Kg/ha-mm for pan evaporimeter. The reduction in crop water use efficiency in furrow irrigation was due to application of excess water, evaporation and reduction in infiltration rate. Aqua crop model yield were always above the harvested yields. Moreover, Montoya et.al (2016) [9] also faced with overestimation when they validated the model for potato. Katerji et al (2013) [6] found over estimation of corn yield and under estimation of evapotranspiration. The model overestimated the yields in every case, but the actual and modelled yields showed good correlation. AquaCrop can be a good option to predict the expectable dry yields in processing tomato, but it needs further data for thorough investigation. That is very important from the farmers point of view for irrigation management planning, since the rate of irrigation water saving can be higher than yield reduction, as it had been found in potato (Linker et al. 2016) [7]. The processing industry’s interest is pointing at the prediction of dry yields also for better using the capacities.

3. Field Water Use Efficiency

Table 4: Comparison of field water use efficiency by using zai pit technology and furrow irrigation method

S. No	Crop	Type of method	Field water use efficiency (kg/ha-mm)
1	Tomato	Zai pit technology	13.84
2		Furrow irrigation method	3.05

From the Table 4 it was observed that, the field water use efficiency was found highest in zaipit technology with the values of 13.84 Kg/ha-mm compared with furrow irrigation method of value 5.18 Kg/ha-mm. This was because zai pit technology provides only net water requirement of crop whereas furrow irrigation provides gross water requirement of crop.

4. Comparison of Yield of Tomato Crop between Zai Pit Technology and Furrow Irrigation

Tomato crop was harvested by manually in the both methods and the yield was calculated and presented in Table 3.4.

Table 5: Comparison of yield of tomato crop between zai pit technology and furrow irrigation method

S. No	Crop	Type of method	Yield (kg/ha)
1	Tomato	Zai pit technology	4081.63
2		Furrow irrigation method	2040.81

From the Table 5 it was observed that yield of zai pit technology was more compared to furrow irrigation method. This was due to concentrate application of organic manure in zai pit technology when compared to furrow irrigation method.

Conclusion

The yield of tomato crop increased twice in zai pit technology (4081.63 Kg/ha) as compare to furrow irrigation

method (2040.81Kg/ha). The field water use efficiency (13.84 Kg/ha-mm) increased as compare to furrow irrigation (3.05 Kg/ha-mm) method. The crop water use efficiency is found highest in zaipit technology with the values of 10.41 Kg/ha-mm in AQUACROP model and 7.97Kg/ha-mm in pan evaporimeter compared with furrow irrigation method values of 5.18 Kg/ha-mm in AQUA CROP model and 3.98 Kg/ha-mm for pan evaporimeter.

References

- Barro et al. Decomposition of organic amendment and nutrient release under the zai technique in the Sahel. Journal on nutrient cycling in Agroecosystems, 2005. ISSN: 1385-1314.
- Dalla Marta A, Chirico GB, FalangaBolognesi S, Mancini M, D’Urso G, Orlandini S, De Michele C, Altobelli F. Integrating sentinel-2 imagery with Aquacrop for dynamic assessment of tomato water requirements in southern Italy. Agronomy,2018;9(7):404.
- Dr. Sawadogo et al. Conducted experiment on that how to optimize the zai system other plant,2011:27:545-766.
- Evelt SR, Howell TA, Baumhardt RL, Copeland KS. Can weighing lysimeter ET represent surrounding field ET well enough to test flux station measurements of daily and sub-daily ET. Adv Water Res,2012a:50:79–90.
- Feder et al. Understanding and promoting adoption of conservation practices by rural landholders. Journal of Australian Journal of Experimental Agriculture,1985:46(11):1407-1424.
- Katerji N, Campi P, Mastrorilli M. Productivity, evapotranspiration, and water use efficiency of corn and tomato crops simulated by AquaCrop under contrasting water stress conditions in the Mediterranean region. Agricultural Water Management,2013:130:14–26.
- Linker R, Ioslovich I, Sylaios G, Plauborg F, Battilani A. Optimal model-based deficit irrigation scheduling using Aqua Crop: A simulation study with cotton, potato and tomato. Agricultural Water Management,2016:163:236–243.
- MN Danjuma et al. Conducted experiment on that zai pit system “A catalyst for restoration in the dry Lands”. IOSR Journal of Agriculture and Veterinary Science (IOSR-JAVS), 2015.
- Montoya F, Camargo D, Ortega JF, Córcoles JJ, Domínguez A. Evaluation of Aquacrop model for a potato crop under different irrigation conditions. Agricultural Water Management,2016:164:267–280.
- Boudhina N, Masmoudi MM, Alaya I, Jacob F, Ben Mechlia N. Use of AquaCrop model for estimating crop evapotranspiration and biomass production in hilly topography. Arabian Journal of Geosciences, Springer,2019:12(8):259.
- Burgy RH et al. A Test of the single- and double-ring types of infiltrometers. Journal of EOS, 1957, 38.
- Rana G, Ferrara RM, Martinelli N, Personnic P, Cellier P. Estimating energy fluxes from sloping crops using standard agrometeorological measurements and topography. Agric For Meteorol,2007:146:116–133.
- Singh PK, Logesh K, Kumar SS, Kannan S, Tejaswini V, Soudagar MEM, Obaid SA. Revolutionizing the material performance of AZ64/ZrB2 composites for engineering applications. Revista Materia, 2025, 1-10.

14. Steduto P, Raes D, Hsiao T, Fereres E, Heng L, Izzi G, Hoogeveen J. AquaCrop: A New Model for Crop Prediction Under Water Deficit Conditions. FAO, Rome, 2008, 33.
15. Twine TE, Kustas WP, Norman JM, Cook DR, Houser PR, Meyers TP, Prueger JH, Starks PJ, Wesely ML. Correcting eddy covariance flux underestimates over a grassland. *Agric For Meteorol*, 2000;103:279–300.
16. Sai Krishna V, Jain SK, Panwar NL, Joshi S, Wadhawan N, Kumar A. Emergence of Internet of Things technology in food and agricultural sector: A review. *Journal of Food Process Engineering*, 2024, 47(8).
17. Tejaswini V, Ravi babu G, Kumar HVH, Prasad BVS, Sujani Rao Ch. Water quality assessment in agricultural drains using PCA techniques. *International Journal of Advanced Biochemistry Research*, 2025;9(5):395-398.